

**NOTE:**  
If your oven does not operate properly, unplug it from the 120 volt household outlet and then plug it back in. This unit is not designed for 50 Hz or any circuit other than 120 volt/60Hz AC current.

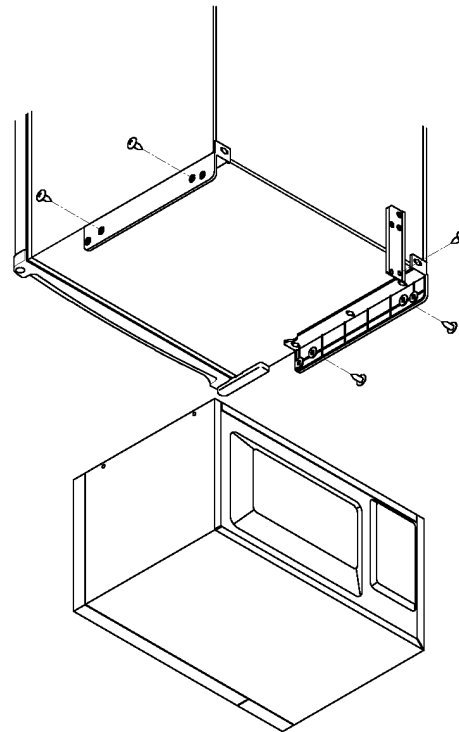

**MicroFridge®  
Model MFRA-3  
Assembly Diagram**

**Installation of Microwave Models**

1. Place the oven on top of the approved MicroFridge® refrigerator carefully lining up screw holes of the refrigerator sash with microwave holes.
2. Do not block the inlet and outlet openings located at the rear and bottom of the oven. Blocking the inlet and/or outlet openings can damage the oven.
3. Do not remove the feet from the bottom of the oven.
4. Attach the microwave oven to the refrigerator by screwing in the four (4) side screws and one (1) rear screw.
5. Screws can be found in the attached bag.
6. Plug your oven and refrigerator into a standard 120-volt/60Hz household outlet. Be sure the electrical circuit is at least fifteen (15) amperes and that your microwave oven is the only appliance on the circuit.

Remove all packing materials and accessories. Examine the oven for any damage, such as dents or broken door. Do not install if the oven is damaged.

**CAUTION:**  
Do not operate your refrigerator near flammable materials such as gasoline. Do not use for storage of flammable materials. Your refrigerator must be grounded. Use a 120 volt, 60 Hz outlet. Do not use an extension cord.  
UNLESS THE ABOVE GROUNDING METHOD IS FOLLOWED, YOU ARE NOT PROTECTED AGAINST SEVERE OR LETHAL SHOCK IN THE EVENT OF A SHORT CIRCUIT OF AN ELECTRICAL COMPONENT OR WIRING OF THE REFRIGERATOR.

1. Ice Compartment: Use it for making ice cubes and short term storage of frozen food.
2. Drip Tray
3. Slide-Out Shelves
4. Glass Shelf with Crisper
5. Adjustable Feet
6. Temperature Control Knob
7. Full-Width Door Shelves
8. 2-Liter Bottle Shelf
9. Defrost Timer
10. Ice Cube Tray

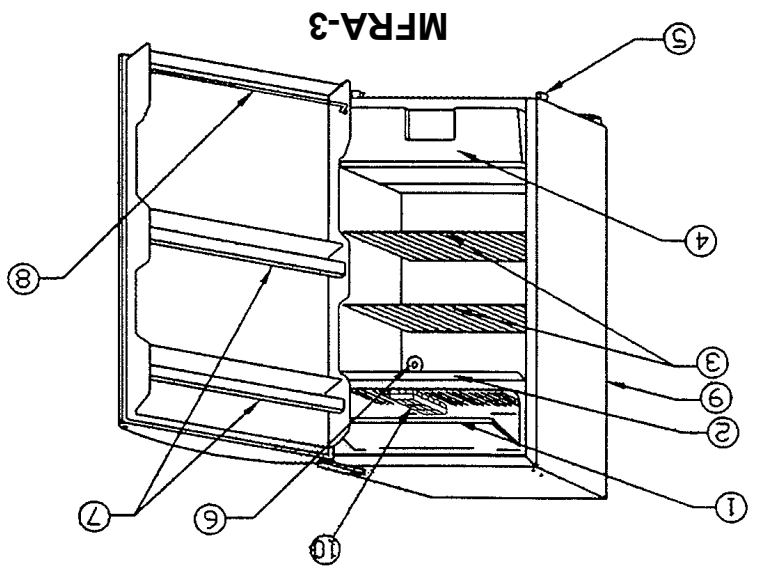

**Parts and Features**

**MicroFridge®, a Product of Intirion Corporation  
Microwave Oven and Refrigerator/Freezer Residential Limited Warranty**

Intirion is pleased to provide a comprehensive warranty on these products. Intirion takes pride in its product and manufacturing standards and warrants its products and parts against defects in materials or workmanship to the original purchaser.

Subassembly	Duration
– Microwave oven magnetron	2 years
– Refrigerator/freezer sealed system and compressor	2 years
– Microwave oven and refrigerator/freezer mechanical components	1 year

All requests for service should be directed to Customer Service at Intirion by calling 1-800-637-7567. Intirion offers a quick response customer service program. Customer Service will diagnose the problem and either replace or the original purchaser will carry-in the appliance to an **authorized service provider** for repair, at the discretion of Intirion.

MicroFridge® warranty services are performed by Intirion **authorized service providers**. Intirion expects prompt, courteous and efficient service. Intirion further expects that all **authorized service providers** will make every reasonable effort to enhance the image and reputation of Intirion and its products. Inadequate service or customer dissatisfaction should be promptly reported to Intirion.

Damage initiated by spark fires caused by using inappropriate material inside the microwave oven is specifically excluded from this warranty. Intirion assumes no liability and does not guarantee or warranty any repairs and/or replacement parts not supplied or performed by an **authorized service provider**, nor any 50/60 cycle or 60/50 cycle conversions, damage caused by failure to follow the owner's manual as to adjustments and/or maintenance, customer adjustments that are not covered in the instruction booklet, broken or marred cabinet, misuse, neglect, accident, fire, flood or other acts of nature.

THIS WARRANTY WILL BECOME INVALID IF ANY SERIAL NUMBER ON THE PRODUCT IS ALTERED, REPLACED, DEFACED OR MISSING. THIS WARRANTY IS FOR INTIRION PRODUCTS PURCHASED AND USED IN THE UNITED STATES EXCEPT FOR UNITED STATES POSSESSIONS AND/OR DOMINIONS OF THE UNITED STATES.

This is the entire Intirion warranty and it may not be changed or amended by any person, agency, distributor, dealer, or company. Intirion assumes no liability and indeed specifically denies responsibility for any consequential damages beyond the repair or replacement of the product or its components.

The warranty period begins on the date of sale and proof of that date (evidenced by an original sales slip or bill of sale) will be necessary to initiate a warranty claim.

MICROFRIDGE®, A PRODUCT OF INTIRION CORPORATION,  
10 Walpole Park South, Walpole MA 02081 **1-800-637-7567**

**INSTRUCTION  
MANUAL**



**MFRA-3  
REFRIGERATOR** by Intirion

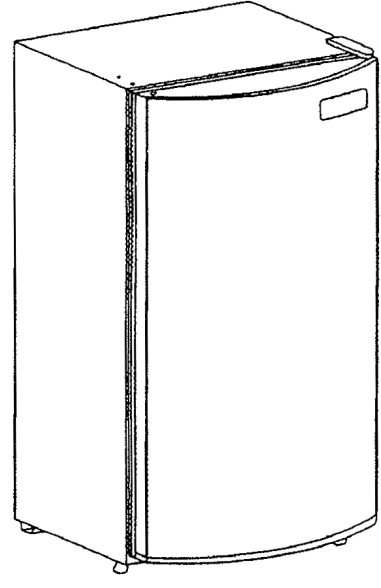

**ATTENTION**

For your protection in the event of theft or loss of refrigerator, fill in spaces provided below. Model and Serial Numbers are indicated on the inside right liner of the refrigerator.

MODEL No. \_\_\_\_\_  
SERIAL No. \_\_\_\_\_

## Where to Place Your MicroFridge®

1. Select a location with a strong, level floor. If the floor is not quite level, adjust the height of the front legs accordingly.
2. Allow four inches of space between the refrigerator's back and the wall, one inch above the refrigerator and one inch on the side.
3. Avoid any direct sunlight and heat. Direct sunlight may affect the enamel coating. Heat sources nearby will cause higher electricity consumption.
4. Avoid very moist places. Too much moisture in the air will cause frost to form very quickly on the evaporator and the refrigerator will have to be defrosted more frequently.
5. Your refrigerator is equipped with a three-prong plug and is grounded to eliminate electrical hazards. In order to make it more effective, it must be plugged into a grounded electrical outlet.

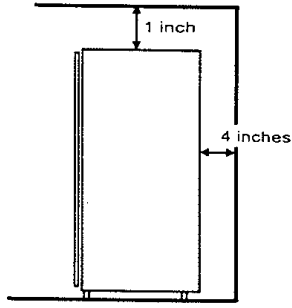

## Test Run Your Refrigerator

Before using your refrigerator, clean it and test run it to see if it is operating properly. If it is not, then check your electrical source. If you cannot locate the source of the problem, contact your dealer.

1. Set the temperature control knob to the *OFF* position and then plug the AC cord into an electrical outlet of 115 volt, 60Hz. The compressor motor should not run.
2. Set the temperature control knob to the *MAX* position and let the refrigerator operate for 20 minutes. The freezer (ice compartment) should get slightly frosted and the motor should run smoothly with a soft hum.
3. Rotate the temperature control knob counter-clockwise toward the *MIN* position. Before the pointer of the temperature control knob reaches the *MIN* position, the compressor motor should turn off.

### ATTENTION

If the unit is turned off or unplugged, **YOU MUST ALLOW THREE (3) MINUTES BEFORE RESTARTING OR REPLUGGING THE UNIT.** The unit will not start if you attempt to restart it in less than three (3) minutes.

## How to Remove Ice Cubes from the Tray

The ice cube tray is flexible. Twist the tray to remove the ice cubes. If the ice cube tray is frozen hard to the surface, do not use a knife or other metal instrument to remove it because this may damage the surface.



## Defrosting

This refrigerator is equipped with an automatic defrost timer so that no manual operation is required for defrosting.

The defrost timer is located on the rear wall of the refrigerator. The black segment of the defrost timer dial (see below) from 0 to 3 covers a 3-hour time span and represents the normal defrosting period the compressor does not operate. The defrost timer will continue to operate and will repeat the 3-hour defrost period once every twenty-four (24) hours as long as the refrigerator is plugged in. The most practical time for automatic defrosting is between midnight and 3:00 a.m.

### Example

If the refrigerator was started at 9:00 a.m., set the timer shaft to the number 9 on the timer dial. If it was started at 6:00 p.m., set the shaft to number 18.

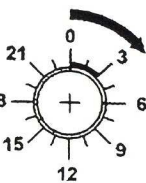

Defrost starting time may be altered by changing the position of the timer shaft as desired. For voluntary defrosting, set the timer shaft to 0. This will start the 3-hour defrosting immediately and after completion the refrigeration cycle will begin again. However, the defrosting cycle will be automatically repeated at the same time every twenty-four (24) hours.

While defrosting, the defrost water is drained out of the cabinet into an evaporating tray on the rear wall of the refrigerator and is evaporated automatically. To set the timer shaft, use a screwdriver and turn the shaft **CLOCKWISE** only.

## Cleaning and Maintenance

Your refrigerator does not require any maintenance.

Turn off your refrigerator and remove all food, shelves, trays, etc. Wash the interior liner with a solution of two tablespoons of baking soda and a quart of warm water. Then, rinse and wipe it out. Do not use soaps, detergents, scouring powders, spray cleaners or the like for cleaning the interior liner, as these may cause odors in the refrigerator compartment.

Wash the ice cube trays, drip tray and shelves in a mild detergent solution and dry with a soft cloth.

Wipe the exterior surface with a soft cloth dampened with soapy water and dry it with a soft cloth. Normal appliance spray cleaners may be used for the exterior only.

Use only mild soap and water to clean the door gasket.

Never use acid, chemical thinners, gasoline, benzene or the like to clean any part of the refrigerator. Boiling water and benzene may deform or damage the plastic parts.

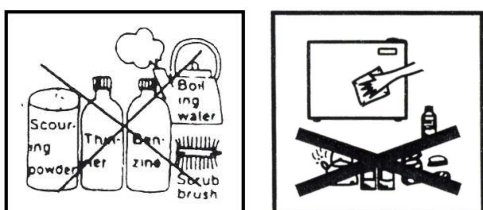

## Temperature Control

You can control the temperature inside your refrigerator by turning the temperature control dial. Dialing toward *MAX* means greater cooling power; toward *MIN* means less cooling power. Set the temperature control dials to *MAX* only when the rapid refrigeration/freezing of foodstuffs in your refrigerator is necessary. Be sure to set it back to *MED* later on.

### Important

- Do not operate your refrigerator for more than six hours at a stretch with the temperature control dial set to *MAX*. At this setting, the compressor will run continuously. Consequently, foodstuffs stored in the refrigerator compartment will be frozen and frost will form on the cooling (evaporator) unit.
- At the control dial setting of *MIN* the freezer compartment temperature will not remain at a sufficiently low level for frozen foods.

Usually the temperature control dial should be set at the *MED* position.

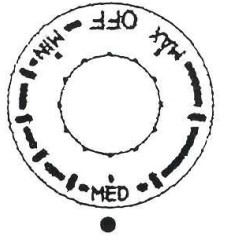

## Before Calling for Service

We urge you to read the chart below. If the problem is not caused by defective workmanship or materials, you may be charged for service calls even during the warranty period. Before calling for service, check these few simple points:

Refrigerator not operating	<ul style="list-style-type: none"> <li>• Is the temperature control dial inside the refrigerator set to OFF?</li> <li>• Is the unit unplugged? Be sure!</li> <li>• Is the fuse blown or the circuit breaker tripped?</li> </ul>
Storage compartment too warm	<ul style="list-style-type: none"> <li>• Has the door been opened frequently? Is it slightly ajar?</li> <li>• Are the shelves overcrowded?</li> <li>• Have large amounts of warm food been added recently?</li> <li>• Are the coils on the back clogged or blocked?</li> <li>• Is the temperature control dial set properly?</li> </ul>
Excessive noise	<ul style="list-style-type: none"> <li>• Is the refrigerator level? (Try to rock it.)</li> <li>• Are dishes vibrating?</li> <li>• Are there objects behind or on top that are shaking?</li> <li>• Does any part of the refrigerator touch the back or side wall?</li> <li>• When the motor comes on, you may hear popping or cracking sounds as metals expand or contract.</li> </ul>
Moisture	<ul style="list-style-type: none"> <li>• Moisture in the storage compartment is normal in humid weather.</li> <li>• Is the door opened frequently? Has the door been left ajar? Does the door fit properly?</li> </ul>

## Changing Door Hinge Location

Refer to the disassembly diagram and change the door hinges according to the following steps.

1. Remove the hinge cap by twisting it off.
2. Remove the upper hexagonal head screws.
3. Remove the lower hexagonal head screws and the leg on the hinge side.
4. Remove the other leg.
5. Attach the bottom hinge with the hinge shaft and the leg symmetrically to the other side of the cabinet.
6. Attach the other leg.
7. Remove the two cabinet plug buttons and remount them in the holes from which the screws were removed in step 2.
8. Remove the door plug button using a screwdriver and insert it in the opposite side of the door.
9. Use the screw to attach the upper hinge and the spacer (if there is any). Do not tighten the screw completely. The direction in which the door opens has now been changed; however, the following points should be checked:
  - a. Make sure the door is on straight.
  - b. Make sure there is no space between the door gasket and the refrigerator unit itself when the door is closed.
  - c. Make sure that the gasket on the hinged side is not caught between the door and the unit when the door is opened or closed. (If the door is forced closed when the gasket is caught, the gasket may be damaged).
10. After making sure that the door is installed correctly, tighten all the screws holding the hinges.

