

NOTE:
The MicroFridge® with Safe Plug® brand refrigerator and charging outlets will not operate when the microwave oven is on. This is part of the patent-pending MicroFridge® with Safe Plug® technology that prevents wiring overload.
If your oven does not operate properly, unplug it from the 120 volt household outlet and then plug it back in. This unit is not designed for 50 Hz or any circuit other than 120 volt/60Hz AC current.

The MicroFridge® with Safe Plug® combination appliance will now operate within eleven (11) to fifteen (15) amps of current draw.

7. Plug the AC cord from the microwave oven into an appropriate, grounded outlet.
6. Plug the refrigerator/freezer AC cord into the outlet on the back of the microwave oven.

5. Place the microwave oven on top of the refrigerator/freezer and inside the microwave oven with those on the two upright sides of the bracket. Line up the two (2) holes on each side of the bracket, and attach the microwave oven on top of the refrigerator/freezer using the screws from Step 1.

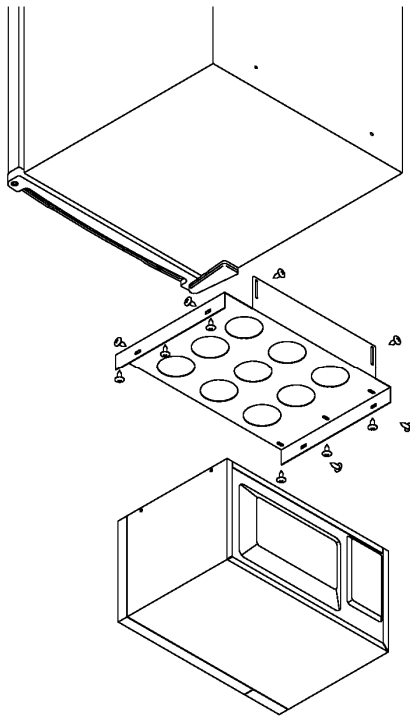

4. Using the screws from Step 1, attach the bracket to the top of the refrigerator/freezer using the six (6) holes located near the two upright sides of the bracket. There are no preset holes in the top of the refrigerator/freezer so apply pressure when installing the screws.
3. Align the holes in the rear lip of the bracket with those on the back of the refrigerator/freezer, and attach using the screws from Step 1.
2. Place the bracket on top of the refrigerator/freezer with its rear lip facing downward over the back edge of the refrigerator/freezer, and the two sides facing up to accept the microwave oven.
1. Locate the microwave oven. Remove the packet of twelve (12) screws located inside the microwave oven. Retain the screws.

MicroFridge® with Safe Plug®
Model 5.6MFR Assembly

Installation of Microwave Models

MicroFridge® with Safe Plug®, a Product of Intirion Corporation Microwave Oven and Refrigerator/Freezer Residential Limited Warranty

Intirion is pleased to provide a comprehensive warranty on these products. Intirion takes pride in its product and manufacturing standards and warrants its products and parts against defects in materials or workmanship to the original purchaser.

Subassembly	Duration
– Microwave oven magnetron	2 years
– Refrigerator/freezer sealed system and compressor	2 years
– Microwave oven and refrigerator/freezer mechanical components	1 year

All requests for service should be directed to Customer Service at Intirion by calling 1-800-637-7567. Intirion offers a quick response customer service program. Customer Service will diagnose the problem and either replace or the original purchaser will carry-in the appliance to an **authorized service provider** for repair, at the discretion of Intirion.

MicroFridge® with Safe Plug® warranty services are performed by Intirion **authorized service providers**. Intirion expects prompt, courteous and efficient service. Intirion further expects that all **authorized service providers** will make every reasonable effort to enhance the image and reputation of Intirion and its products. Inadequate service or customer dissatisfaction should be promptly reported to Intirion.

Damage initiated by spark fires caused by using inappropriate material inside the microwave oven is specifically excluded from this warranty. Intirion assumes no liability and does not guarantee or warranty any repairs and/or replacement parts not supplied or performed by an **authorized service provider**, nor any 50/60 cycle or 60/50 cycle conversions, damage caused by failure to follow the owner's manual as to adjustments and/or maintenance, customer adjustments that are not covered in the instruction booklet, broken or marred cabinet, misuse, neglect, accident, fire, flood or other acts of nature.

THIS WARRANTY WILL BECOME INVALID IF ANY SERIAL NUMBER ON THE PRODUCT IS ALTERED, REPLACED, DEFACED OR MISSING. THIS WARRANTY IS FOR INTIRION PRODUCTS PURCHASED AND USED IN THE UNITED STATES EXCEPT FOR UNITED STATES POSSESSIONS AND/OR DOMINIONS OF THE UNITED STATES.

This is the entire Intirion warranty and it may not be changed or amended by any person, agency, distributor, dealer, or company. Intirion assumes no liability and indeed specifically denies responsibility for any consequential damages beyond the repair or replacement of the product or its components.

The warranty period begins on the date of sale and proof of that date (evidenced by an original sales slip or bill of sale) will be necessary to initiate a warranty claim.

MICROFRIDGE® WITH SAFE PLUG®, A PRODUCT OF INTIRION CORPORATION,
10 Walpole Park South, Walpole MA 02081 **1-800-637-7567**

CAUTION:
Do not operate your refrigerator near flammable materials such as gasoline. Do not use for storage of flammable materials. Your refrigerator must be grounded. Use a 120 volt, 60 Hz outlet. If you are using this refrigerator as part of a MicroFridge® with Safe Plug® combination appliance, you must use the 120 V/60 Hz outlet located on the back of the Microwave Oven in order to take advantage of patent-pending Safe Plug® technology to limit electrical draw. Do not use an extension cord.
Use a 3-prong plug with the 3-prong grounded outlet on the Microwave Oven. (This is the only method that complies with the National Electric Code, local codes and ordinances.)
UNLESS THE ABOVE GROUNDING METHOD IS FOLLOWED, YOU ARE NOT PROTECTED AGAINST SEVERE OR LETHAL SHOCK IN THE EVENT OF A SHORT CIRCUIT OF AN ELECTRICAL COMPONENT OR WIRING OF THE REFRIGERATOR.
When you start this refrigerator from the Microwave Oven Power Supply: Do NOT plug in while the Microwave Oven is working. WAIT at least three (3) minutes after using the Microwave Oven before plugging in the refrigerator because the electricity will be cut off during this period.

1. **Ice Compartment:** Use it for making ice cubes and short term storage of frozen food.
2. **Temperature Control with Push-Button Defrost**
3. **Full-Width Door Shelves**
4. **2-Liter Shelf**
5. **Interior Light**
6. **Interior Light Switch**
7. **Adjustable Feet**
8. **Slide Out Shelves**
9. **Drip Tray**
10. **Glass Shelf with Crisper**
11. **Ice Cube Tray (inside ice compartment)**

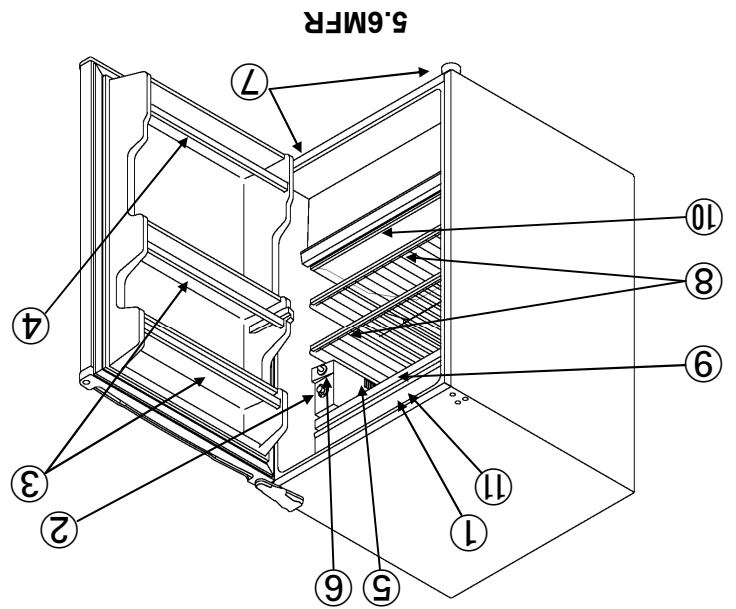

Parts and Features

INSTRUCTION MANUAL



5.6MFR

by Intirion

REFRIGERATOR

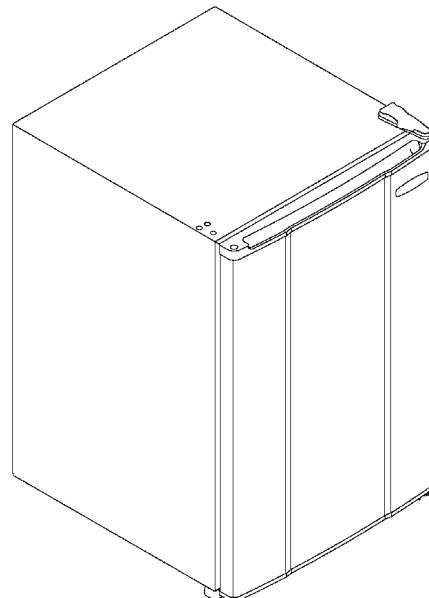

What is Safe Plug® Technology?

MicroFridge® combination appliances utilize Safe Plug® technology, a revolutionary, patent-pending design, to conserve electricity and reduce potential fire hazards that can be caused by overloaded circuits. This technology, built into the microwave, works by temporarily shutting off the power to the refrigerator and charging outlets when the microwave is in use. When the microwave is finished, power to the refrigerator and charging outlets resumes. Engineered with unique one-plug-to-the-wall operation, our combination appliances never draw more than 11-15 amps of current.

MicroFridge® with Safe Plug® uses patent-pending intelligent load monitoring technology to control the microwave, refrigerator and extra outlets. The two charging outlets are designed to conveniently re-charge cell phones, digital cameras, laptops or similar low power devices.

ATTENTION

For your protection in the event of theft or loss of refrigerator, fill in spaces provided below. Model and Serial Numbers are indicated on the inside right liner of the refrigerator.

MODEL No. _____
SERIAL No. _____

Where to Place Your MicroFridge® with Safe Plug®

1. Select a location with a strong, level floor. If the floor is not quite level, adjust the height of the front legs accordingly.
2. Allow four inches of space between the refrigerator's back and the wall, one inch above the refrigerator and one inch on the side.
3. Avoid any direct sunlight and heat. Direct sunlight may affect the enamel coating. Heat sources nearby will cause higher electricity consumption.
4. Avoid very moist places. Too much moisture in the air will cause frost to form very quickly on the evaporator and the refrigerator will have to be defrosted more frequently.
5. Your refrigerator is equipped with a three-prong plug and is grounded to eliminate electrical hazards. In order to make it more effective, it must be plugged into a grounded electrical outlet.
6. Plug your refrigerator in the back of the microwave.

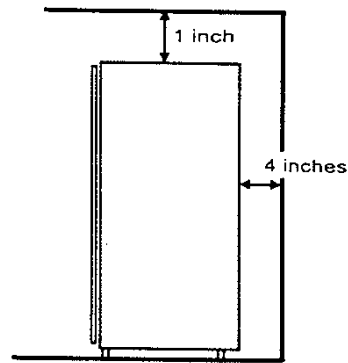

Test Run Your Refrigerator

Before using your refrigerator, clean it and test run it to see if it is operating properly. If it is not, then check your electrical source. If you cannot locate the source of the problem, contact your dealer.

1. Set the temperature control knob to the "OFF" position and then plug the AC cord into an electrical outlet of 115 volt, 60Hz. The compressor motor should not run.
2. Set the temperature control knob to the "MAX" position and let the refrigerator operate for 20 minutes. The freezer should get slightly frosted and the motor should run smoothly with a soft hum.
3. Rotate the temperature control knob counter-clockwise toward the "MIN" position. Before the pointer of the temperature control knob reaches the "MIN" position, the compressor motor should turn off.

ATTENTION

If the unit is turned off or unplugged, **YOU MUST ALLOW THREE (3) MINUTES BEFORE RESTARTING OR REPLUGGING THE UNIT.** The unit will not start if you attempt to restart it in less than three (3) minutes.

Cleaning and Maintenance

Your refrigerator does not require any maintenance.

Turn off your refrigerator and remove all food, shelves, trays, etc. Wash the interior liner with a solution of two tablespoons of baking soda and a quart of warm water. Then, rinse and wipe it out. Do not use soaps, detergents, scouring powders, spray cleaners or the like for cleaning the interior liner. It may cause odors in the refrigerator compartment.

Wash the ice cube trays, drip tray and shelves in a mild detergent solution and dry with a soft cloth.

Wipe the exterior surface with a soft cloth dampened with soapy water and dry it with a soft cloth. Normal appliance spray cleaners may be used for the exterior only.

Use only mild soap and water to clean the door gasket.

Never use acid, chemical thinners, gasoline, benzene or the like to clean any part of the refrigerator. Boiling water and benzene may deform or damage the plastic parts.



Before Calling for Service

We urge you to read the chart below. If the problem is not caused by defective workmanship or materials, you may be charged for service calls even during the warranty period. Before calling for service, check these few simple points:

Refrigerator not operating	<ul style="list-style-type: none"> • Is the temperature control dial inside the refrigerator set to OFF? • Is the unit unplugged? Be sure! • Is the fuse blown or the circuit breaker tripped?
Storage compartment too warm	<ul style="list-style-type: none"> • Has the door been opened frequently? Is it slightly ajar? • Are the shelves overcrowded? • Have large amounts of warm food been added recently? • Are the coils on the back clogged or blocked? • Is the temperature control dial set properly?
Excessive noise	<ul style="list-style-type: none"> • Is the refrigerator level? (Try to rock it.) • Are dishes vibrating? • Are there objects behind or on top that are shaking? • Does any part of the refrigerator touch the back or side wall? • When the motor comes on, you may hear popping or cracking sounds as metals expand or contract.
Moisture	<ul style="list-style-type: none"> • Moisture in the storage compartment is normal in humid weather. • Is the door opened frequently? Has the door been left ajar? • Does the door fit properly?

Temperature Control

You can control the temperature inside your refrigerator by turning the thermostat dial. Higher numbers mean greater cooling power, smaller numbers mean less cooling power. Set the temperature control dial to "3" for optimum refrigeration/freezing effects under normal conditions. Set the temperature control dials to "MAX" only when the rapid refrigeration/freezing of foodstuffs in your refrigerator is necessary. Be sure to set it back to "3" later on.

Important

- Do not operate your refrigerator for more than six hours at a stretch with the temperature control dial set to 5 or MAX. At this setting, the compressor will run continuously. Consequently, foodstuffs stored in the refrigerator compartment will be frozen and frost will form on the cooling (evaporator) unit.
- At the control dial setting of MIN, the ice compartment temperature will not remain at a sufficiently low level for ice to remain frozen solid.

How to Defrost

For the most efficient operation of your refrigerator, defrost it whenever a 1/4" thick layer of ice/frost forms on the walls of the ice compartment.

When defrosting your refrigerator, remove all food from the refrigerator and put the drip tray in place. To begin defrosting, simply push the defrost button at the center of the temperature control knob. When defrosting is completed, the refrigerator will restart the cooling operation automatically. After defrosting, discard the water in the drip tray and replace the food back to the refrigerator.

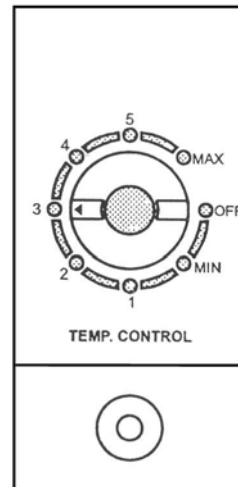

NOTE: Never use any sharp or metallic instruments to remove ice/frost from the ice compartment. A punctured evaporator will cause serious problems to your refrigerator and void the warranty. Also, do not use boiling water to defrost.

How to Remove Ice Cubes from the Tray

The ice cube tray is flexible. Twist the tray to remove the ice cubes. If the ice cube tray is frozen hard to the surface, do not use a knife or other metal instrument to remove it because this may damage the surface.



Changing Door Hinge Location

Refer to the disassembly diagram and change the door hinges according to the following steps.

1. Remove the hinge cap by twisting it off.
2. Remove the upper hexagonal head screws.
3. Remove the lower hexagonal head screws and the leg on the hinge side.
4. Remove the other leg.
5. Attach the bottom hinge with the hinge shaft and the leg symmetrically to the other side of the cabinet.
6. Attach the other leg.
7. Remove the two cabinet plug buttons and remount them in the holes from which the screws were removed in step 2.
8. Remove the door plug button using a screwdriver and insert it in the opposite side of the door.
9. Use the screw to attach the upper hinge and the spacer (if there is any). Do not tighten the screw completely. The direction in which the door opens has now been changed; however, the following points should be checked:
 - a. Make sure the door is on straight.
 - b. Make sure there is no space between the door gasket and the refrigerator unit itself when the door is closed.
 - c. Make sure that the gasket on the hinged side is not caught between the door and the unit when the door is opened or closed. (If the door is forced closed when the gasket is caught, the gasket may be damaged).
10. After making sure that the door is installed correctly, tighten all the screws holding the hinges.

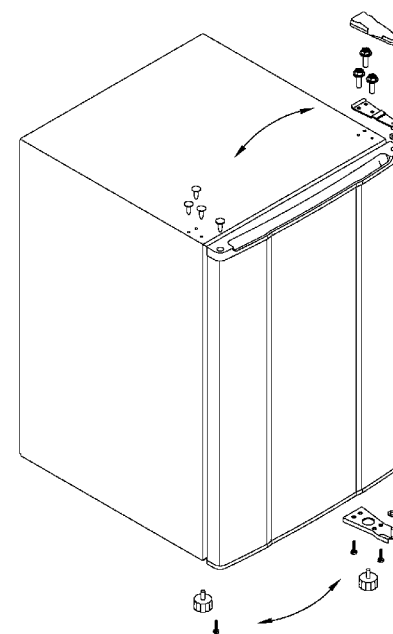

Installing the Hinge Clip

1. Remove Cord Retaining Clip from bag.

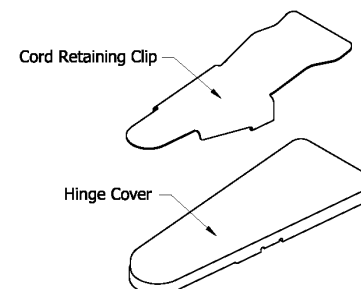

2. Slide Cord Retaining Clip to Hinge Cover until it stops.

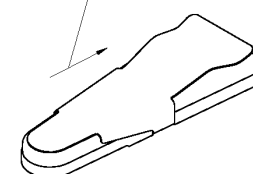

WARNING:

Do not route high-voltage electrical cords underneath the hinge clip. Only use the clip to cover low-voltage electrical cords.