

NOTE:
The MicroFridge® with Safe Plug® brand refrigerator and charging outlets will not operate when the microwave oven is on. This is part of the patent-pending MicroFridge® with Safe Plug® technology that prevents wiring overload.
If your oven does not operate properly, unplug it from the 120 volt household outlet and then plug it back in. This unit is not designed for 50 Hz or any circuit other than 120 volt/ 60Hz AC current.

The MicroFridge® with Safe Plug® combination appliance will now operate within eleven (11) to fifteen (15) amps of current draw.

9. Plug the AC cord from the microwave oven into an appropriate, grounded outlet.
8. Plug the refrigerator/freezer AC cord into the outlet on the back of the microwave oven.
7. Place the microwave oven on top of the refrigerator/freezer and inside the two upright sides of the brackets. Line up the two (2) holes on each side of the microwave oven with those on the brackets, and attach the microwave oven using the screws from Step 1.
6. To finish installing the left bracket please repeat steps 3 and 4.

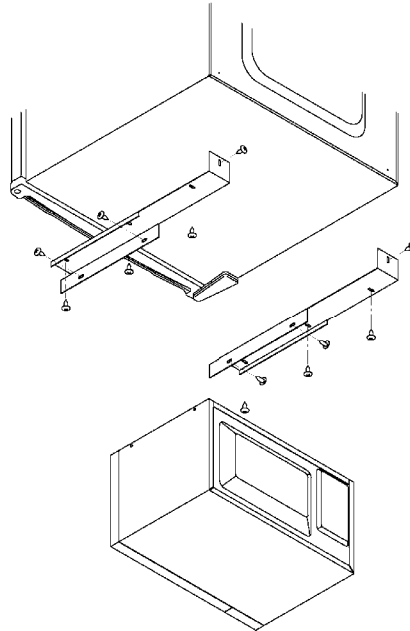

5. Place the left bracket flush with the top left side of the refrigerator/freezer with its rear lip facing downward over the back edge of the refrigerator/freezer, the shorter bend without holes should face outward.
4. Using the screws from Step 1, attach the bracket(s) to the top of the refrigerator/freezer using the three (3) holes located on the bottom of the bracket. There are no preset holes in the top of the refrigerator/freezer so apply pressure when installing the screws.
3. Align the hole in the rear lip of the bracket with the hole on the back of the refrigerator/freezer, and attach using the screws from Step 1.
2. Place the right bracket flush with the top right side of the refrigerator/freezer with its rear lip facing downward over the back edge of the refrigerator/freezer, the shorter bend without holes should face outward.
1. Locate the microwave oven. Remove the packet of twelve (12) screws located inside the microwave oven. Retain the screws.

MicroFridge® with Safe Plug®
Models 10.3RMFR/10.3LMFR

Installation of Microwave Models

MicroFridge® with Safe Plug®, a Product of Intirion Corporation Microwave Oven and Refrigerator/Freezer Residential Limited Warranty

Intirion is pleased to provide a comprehensive warranty on these products. Intirion takes pride in its product and manufacturing standards and warrants its products and parts against defects in materials or workmanship to the original purchaser.

Subassembly	Duration
– Microwave oven magnetron	2 years
– Refrigerator/freezer sealed system and compressor	2 years
– Microwave oven and refrigerator/freezer mechanical components	1 year

All requests for service should be directed to Customer Service at Intirion by calling 1-800-637-7567. Intirion offers a quick response customer service program. Customer Service will diagnose the problem and either replace or the original purchaser will carry-in the appliance to an **authorized service provider** for repair, at the discretion of Intirion.

MicroFridge® with Safe Plug® warranty services are performed by Intirion **authorized service providers**. Intirion expects prompt, courteous and efficient service. Intirion further expects that all **authorized service providers** will make every reasonable effort to enhance the image and reputation of Intirion and its products. Inadequate service or customer dissatisfaction should be promptly reported to Intirion.

Damage initiated by spark fires caused by using inappropriate material inside the microwave oven is specifically excluded from this warranty. Intirion assumes no liability and does not guarantee or warranty any repairs and/or replacement parts not supplied or performed by an **authorized service provider**, nor any 50/60 cycle or 60/50 cycle conversions, damage caused by failure to follow the owner's manual as to adjustments and/or maintenance, customer adjustments that are not covered in the instruction booklet, broken or marred cabinet, misuse, neglect, accident, fire, flood or other acts of nature.

THIS WARRANTY WILL BECOME INVALID IF ANY SERIAL NUMBER ON THE PRODUCT IS ALTERED, REPLACED, DEFACED OR MISSING. THIS WARRANTY IS FOR INTIRION PRODUCTS PURCHASED AND USED IN THE UNITED STATES EXCEPT FOR UNITED STATES POSSESSIONS AND/OR DOMINIONS OF THE UNITED STATES.

This is the entire Intirion warranty and it may not be changed or amended by any person, agency, distributor, dealer, or company. Intirion assumes no liability and indeed specifically denies responsibility for any consequential damages beyond the repair or replacement of the product or its components.

The warranty period begins on the date of sale and proof of that date (evidenced by an original sales slip or bill of sale) will be necessary to initiate a warranty claim.

MICROFRIDGE® WITH SAFE PLUG®, A PRODUCT OF INTIRION CORPORATION,
10 Walpole Park South, Walpole MA 02081 **1-800-637-7567**

CAUTION:
Do not operate your refrigerator near flammable materials such as gasoline. Do not use for storage of flammable materials. Your refrigerator must be grounded. Use a 120 volt, 60 Hz outlet. If you are using this refrigerator as part of a MicroFridge® with Safe Plug® combination appliance, you must use the 120 V/60 Hz outlet located on the back of the Microwave Oven in order to take advantage of patent-pending Safe Plug® technology to limit electrical draw. Do not use an extension cord.
Use a 3-prong plug with the 3-prong grounded outlet on the Microwave Oven. (This is the only method that complies with the National Electric Code, local codes and ordinances.)
UNLESS THE ABOVE GROUNDING METHOD IS FOLLOWED, YOU ARE NOT PROTECTED AGAINST SEVERE OR LETHAL SHOCK IN THE EVENT OF A SHORT CIRCUIT OF AN ELECTRICAL COMPONENT OR WIRING OF THE REFRIGERATOR.
When you start this refrigerator from the Microwave Oven Power Supply: Do NOT plug in while the Microwave Oven is working. WAIT at least three (3) minutes after using the Microwave Oven before plugging in the refrigerator because the electricity will be cut off during this period.

1. Discharge Outlet for Cold Air: Since cold air flows through this outlet into the refrigerator, be sure to avoid blocking it with stored food.
2. Suction Inlet
3. Temperature Controls
4. Slide-Out Shelves
5. Freezer Shelf
6. Glass Shelf with Crisper
7. Interior Light
8. Interior Light Switch
9. Evaporating Tray: (not shown)
10. Ice Cube Trays
11. Full-Width Door Shelves
12. 2-Liter Door Shelf
13. Adjustable Feet

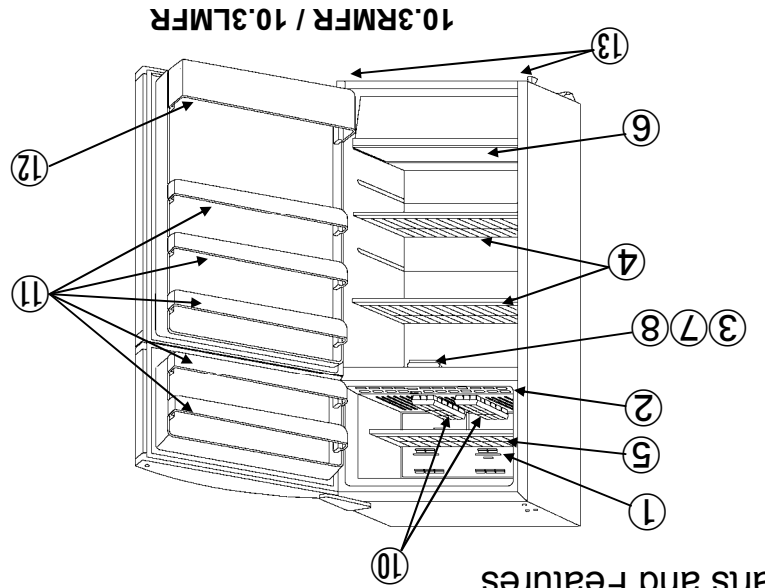

Parts and Features

INSTRUCTION MANUAL



10.3RMFR, 10.3LMFR

by Intirion

REFRIGERATOR/FREEZER

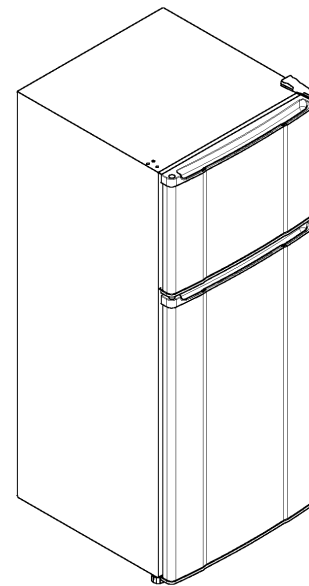

What is Safe Plug® Technology?

MicroFridge® combination appliances utilize Safe Plug® technology, a revolutionary, patent-pending design, to conserve electricity and reduce potential fire hazards that can be caused by overloaded circuits. This technology, built into the microwave, works by temporarily shutting off the power to the refrigerator and charging outlets when the microwave is in use. When the microwave is finished, power to the refrigerator and charging outlets resumes. Engineered with unique one-plug-to-the-wall operation, our combination appliances never draw more than 11-15 amps of current.

MicroFridge® with Safe Plug® uses patent-pending intelligent load monitoring technology to control the microwave, refrigerator and extra outlets. The two charging outlets are designed to conveniently re-charge cell phones, digital cameras, laptops or similar low power devices.

ATTENTION

For your protection in the event of theft or loss of refrigerator, fill in spaces provided below. Model and Serial Numbers are indicated on the inside right liner of the refrigerator.

MODEL No. _____
SERIAL No. _____

Where to Place Your MicroFridge® with Safe Plug®

1. Select a location with a strong, level floor. If the floor is not quite level, adjust the height of the front legs accordingly.
2. Allow four inches of space between the refrigerator's back and the wall, one inch above the refrigerator and one inch on the side.
3. Avoid any direct sunlight and heat. Direct sunlight may affect the enamel coating. Heat sources nearby will cause higher electricity consumption.
4. Avoid very moist places. Too much moisture in the air will cause frost to form very quickly on the evaporator and the refrigerator will have to be defrosted more frequently.
5. Your refrigerator is equipped with a three-prong plug and is grounded to eliminate electrical hazards. In order to make it more effective, it must be plugged into a grounded electrical outlet.

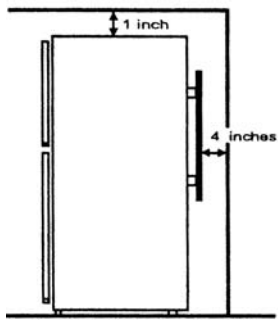

Test Your Refrigerator

Before using your refrigerator, clean it and test run it to see if it is operating properly. If it is not, then check your electrical source. If you cannot locate the source of the problem, contact your dealer.

1. Set the temperature control knob to the *OFF* position and then plug the AC cord into an electrical outlet of 115 volt, 60Hz. The compressor motor should not run.
2. Set the temperature control knob to the *MAX* position and let the refrigerator operate for 20 minutes. The freezer should get slightly frosted and the motor should run smoothly with a soft hum.
3. Rotate the temperature control knob counter-clockwise toward the *MIN* position. Before the pointer of the temperature control knob reaches the *MIN* position, the compressor motor should turn off.

Sound of Flowing is Noticeable

This sound is caused by the refrigerant flowing into the refrigerating device. It does not denote a malfunction.

How to Remove Ice cubes from the Tray

The ice cube tray is flexible. Twist the tray to remove the ice cubes. If the ice cube tray is frozen hard to the surface, do not use a knife or other metal instrument to remove it because this may damage the surface.



Cleaning and Maintenance

Your refrigerator does not require any maintenance.

Turn off your refrigerator and remove all food, shelves, trays, etc. Wash the interior liner with a solution of two tablespoons of baking soda and a quart of warm water. Then, rinse and wipe it out. Do not use soaps, detergents, scouring powders, spray cleaners or the like for cleaning the interior liner. It may cause odors in the refrigerator compartment.

Wash the ice cube trays, drip tray and shelves in a mild detergent solution and dry with a soft cloth. Normal appliance spray cleaners may be used for the exterior only.

Use only mild soap and water to clean the door gasket.

Never use acid, chemical thinners, gasoline, benzene or the like to clean any part of the refrigerator. Boiling water and benzene may deform or damage the plastic parts.



Cleaning the Evaporating Tray

Since dust accumulated on the evaporating tray will decrease the evaporation efficiency, remove the tray to clean.

The evaporating tray is set on the back of the refrigerator. To remove tray, remove screws and pull tray away from the unit. After cleaning make sure to put the tray securely back in place otherwise defrosted water may spill or the evaporation process may be hindered.

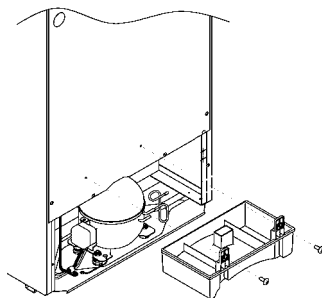

Hot-Line

With the refrigerator/freezer in operation, it is possible that the cabinet will feel warm at the front edges. This does not indicate trouble. It is attributable to the hot gas line design. This prevents moisture from accumulating and has nothing to do with the storage temperature inside.

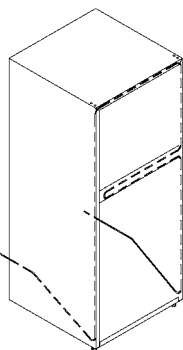

Temperature Control

You can control the temperature inside your refrigerator by turning the temperature control dial. Higher numbers mean greater cooling power; smaller numbers mean less cooling power.

Refrigerator

Set the temperature control dial to 3 for optimum refrigeration effects under normal conditions. Set the temperature control dial to *MAX* only when rapid cooling in your refrigerator is necessary. Be sure to set it back to 3 later on.

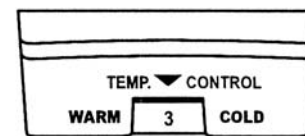

Freezer

For ordinary use, set the temperature control in the *MED* position. For rapid freezing of foodstuffs or to make ice cubes in a hurry, set the knob to the *COLD* position. Do not forget to set the temperature control back to *MED* once the rapid freezing process has been completed.

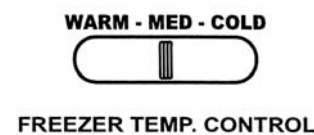

Important

- Do not operate your refrigerator for more than six hours at a stretch with the temperature control dial set to 5 or *MAX*. At this setting, the compressor will run continuously. Consequently, foodstuffs stored in the refrigerator compartment will be frozen and frost will form on the cooling (evaporator) unit.
- At the control dial setting of 1, the freezer compartment temperature will not remain at a sufficiently low level for ice cream and frozen foods.

ATTENTION

If the unit is turned off or unplugged, **YOU MUST ALLOW THREE (3) MINUTES BEFORE RESTARTING OR REPLUGGING THE UNIT.** The unit will not start if you attempt to restart it in less than three (3) minutes.

Changing Door Hinge Location

The door of the refrigerator can be hinged on either side so that the direction they open in can be chosen to suit the place of installation. Refer to the disassembly diagram and change the door hinges according to the following steps:

1. Remove the hinge cap by twisting it off.
2. Remove the upper hexagonal head screws. The freezer door can now be removed.
3. Remove the middle hexagonal head screws. The refrigerator door can now be removed.
4. Remove the right side leg, attach it to the other side hole which is positioned symmetrically.
5. Remove the left side leg, attach it to the other side hole which was positioned symmetrically.
6. Attach the bottom hinge symmetrically to the other side of the cabinet.
7. Remove the upper hinge plug buttons and insert them in the holes from which the screws were removed in Step 2.
8. Remove the middle hinge plastic cover and remount it to cover the holes from which the screws were removed in Step 3.
9. Remove the door plug button from the top of each door using a screwdriver and insert in the hole on the opposite side of each door.
10. Attach the refrigerator door to the bottom hinge.
11. Rotate the middle hinge 180 degrees. Attach it to the refrigerator door and secure it with a screw. (Do not tighten the screw completely.)
12. Attach the upper hinge to the freezer door. Attach the freezer to the middle hinge and use the screw to attach the upper hinge. (Do not tighten the screw completely.)
13. The direction in which the doors open has now been changed; however, the following points should be checked:
 - A) Make sure both doors are on straight.
 - B) Make sure that there is no space between the door gasket and the refrigerator unit itself when the doors are closed.
 - C) Make sure that the gasket on the hinged side is not caught between the door and the unit when the door is opened or closed. (If the door is forced closed when the gasket is caught, the gasket may be damaged.)
14. After making sure that the doors are installed correctly, tighten all the screws holding the hinges. If they are not tightened, the doors may slip out of position or there may be an opening between the doors and the cabinet.
15. For models with senior living handles, remove the screws holding the handle on the door. Remove plastic pins from the other side of the door and insert them into the holes where the screws were removed. Re-install the handle using the same screws that were removed from the door handles.

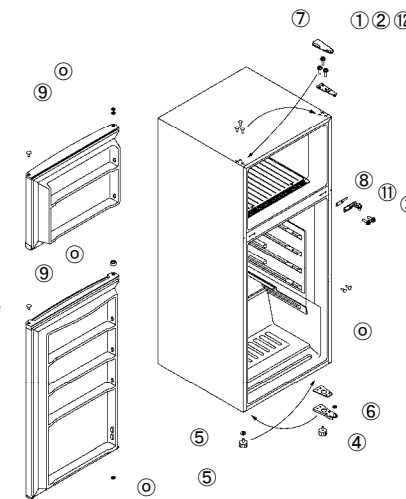

Installing the Hinge Clip

1. Remove Cord Retaining Clip from bag.

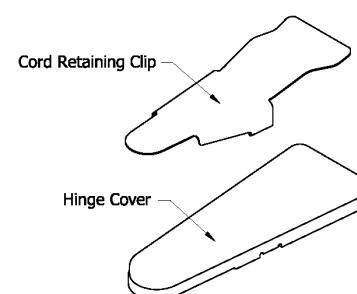

2. Slide Cord Retaining Clip to Hinge Cover until it stops.

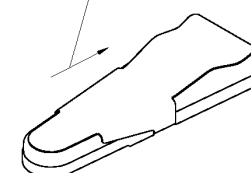

WARNING:

Do not route high-voltage electrical cords underneath the hinge clip. Only use the clip to cover low-voltage electrical cords.