

**NOTE:**  
The MicroFridge® with Safe Plug® brand refrigerator and charging outlets will not operate when the oven is on. This is part of the patented MicroFridge® with Safe Plug® technology that prevents wiring overload.  
If your oven does not operate properly, unplug it from the 15 volt household outlet and then plug it back in. This unit is not designed for 50 Hz or any circuit other than 115 volt/60Hz AC current.

The MicroFridge® with Safe Plug® combination appliance will now operate with eleven (11) - fifteen (15) amps of current draw.  
4. Plug your oven into a standard 115-volt/60Hz household outlet. Be sure the electrical circuit is at least fifteen (15) amperes and that your microwave oven is the only appliance on the circuit.  
● The socket is intended for use with approved MicroFridge® with Safe Plug® refrigerators. Use of this socket for other appliances may be hazardous.

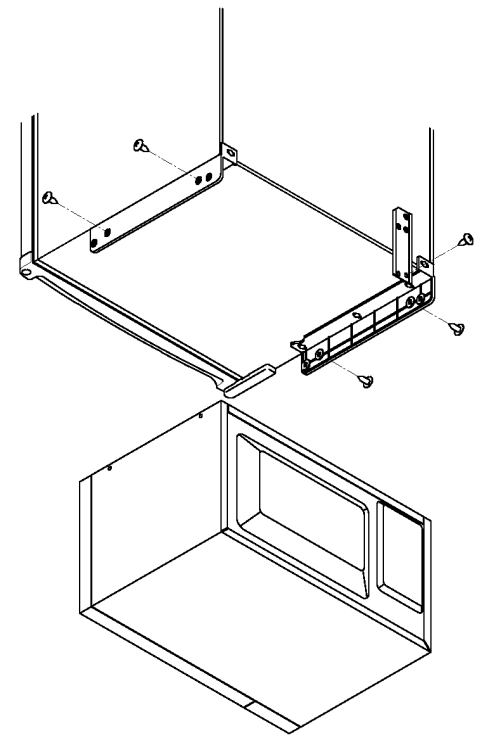

MicroFridge® with Safe Plug®  
Assembly Diagram - Model 3.0MF4R

### Installation of Microwave Models

### MicroFridge® with Safe Plug®, a Product of INTIRION™ Corporation Microwave Oven and Refrigerator/Freezer Residential Limited Warranty

INTIRION, a division of Danby Limited, is pleased to provide a comprehensive warranty on these products. INTIRION takes pride in its product and manufacturing standards and warrants its products and parts against defects in materials or workmanship to the original purchaser.

Subassembly	Duration
– Microwave oven magnetron	2 years
– Refrigerator/freezer sealed system and compressor	2 years
– Microwave oven and refrigerator/freezer mechanical components	1 year

All requests for service should be directed to Customer Service at INTIRION by calling 1-800-637-7567 if you are located in the U.S., and 1-800-263-2629 if you are located in Canada. INTIRION offers a quick response customer service program. Customer service will diagnose the problem and either replace or the original purchaser will carry-in the appliance to an authorized service provider for repair, at the discretion of INTIRION.

MicroFridge® with Safe Plug® warranty services are performed by INTIRION authorized service providers. INTIRION expects prompt, courteous and efficient service. INTIRION further expects that all authorized service providers will make every reasonable effort to enhance the image and reputation of INTIRION and its products. Inadequate service or customer dissatisfaction should be promptly reported to INTIRION.

Damage initiated by spark fires caused by using inappropriate material inside the microwave oven is specifically excluded from this warranty. INTIRION assumes no liability and does not guarantee or warrant any repairs and/or replacement parts not supplied or performed by an authorized service provider, nor any 50/60 cycle or 60/50 cycle conversions, damage caused by failure to follow the owner's manual as to adjustments and/or maintenance, customer adjustments that are not covered in the instruction booklet, broken or marred cabinet, misuse, neglect, accident, fire, flood or other acts of nature.

THIS WARRANTY WILL BECOME INVALID IF ANY SERIAL NUMBER ON THE PRODUCT IS ALTERED, REPLACED, DEFACED OR MISSING. THIS WARRANTY IS FOR INTIRION PRODUCTS PURCHASED AND USED IN THE UNITED STATES AND CANADA EXCEPT FOR UNITED STATES POSSESSIONS AND/OR DOMINIONS OF THE UNITED STATES.

This is the entire INTIRION warranty and it may not be changed or amended by any person, agency, distributor, dealer, or company. INTIRION assumes no liability and indeed specifically denies responsibility for any consequential damages beyond the repair or replacement of the product or its components.

The warranty period begins on the date of sale and proof of that date (evidenced by an original sales slip or bill of sale) will be necessary to initiate a warranty claim.

MICROFRIDGE® WITH SAFE PLUG® A PRODUCT OF INTIRION CORPORATION, A DIVISION OF DANBY PRODUCTS LIMITED

2 Annette Road, Suite 3, Foxborough, MA 02035 1-800-637-7567 U.S. Customers  
PO Box 1778, Guelph, Ontario, Canada N1H 6Z9 1-800-263-2629 Canada Customers

Part No. 8336460122000  
PR2970MF\*

Printed in Mexico

**CAUTION:**  
Do not operate your refrigerator near flammable materials such as gasoline. Do not use for storage of flammable materials. Your refrigerator must be grounded. Use a 15 volt, 60 Hz outlet. If you are using this refrigerator as part of a MicroFridge® with Safe Plug® combination appliance, you must use the 15 V/60 Hz outlet located on the back of the Microwave Oven in order to take advantage of patent-pending Safe Plug® technology to limit electrical draw. Do not splice cord. Do not use an extension cord.  
Use a 3-prong plug with the 3-prong grounded outlet on the Microwave Oven. (This is the only method that complies with the National Electric Code, local codes and ordinances.)  
**UNLESS THE ABOVE GROUNDING METHOD IS FOLLOWED, YOU ARE NOT PROTECTED AGAINST SEVERE OR LETHAL SHOCK IN THE EVENT OF A SHORT CIRCUIT OF AN ELECTRICAL COMPONENT OR WIRING OF THE REFRIGERATOR.**  
When you start this refrigerator from the Microwave Oven Power Supply: Do NOT plug in while the Microwave Oven is working. WAIT at least three (3) minutes after using the Microwave Oven before plugging in the refrigerator because the electricity will be cut off during this period.  
Consult a qualified electrician if the grounding instructions are not completely understood, or if doubt exists as to whether the appliance is properly grounded.

1. Freezer
2. Ice Cube Tray
3. Wire Shelf
4. Glass Shelf
5. Crisper
6. Adjustable Feet
7. Temperature Control Knob
8. Small Item Rack
9. 2-Liter Door Shelf
10. Evaporating Tray (on rear bottom of unit)
11. Ice Scraper

Please ensure that component parts shall be replaced with like components and that servicing shall be done by factory authorized service personnel, so as to minimize the risk of possible ignition due to incorrect parts or improper service.

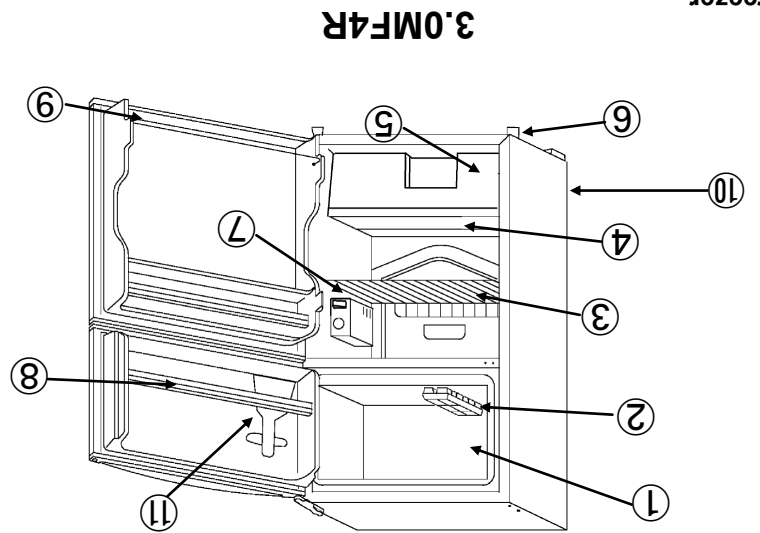

### Parts and Features

## INSTRUCTION MANUAL



### 3.0MF4R

by INTIRION

## REFRIGERATOR/FREEZER

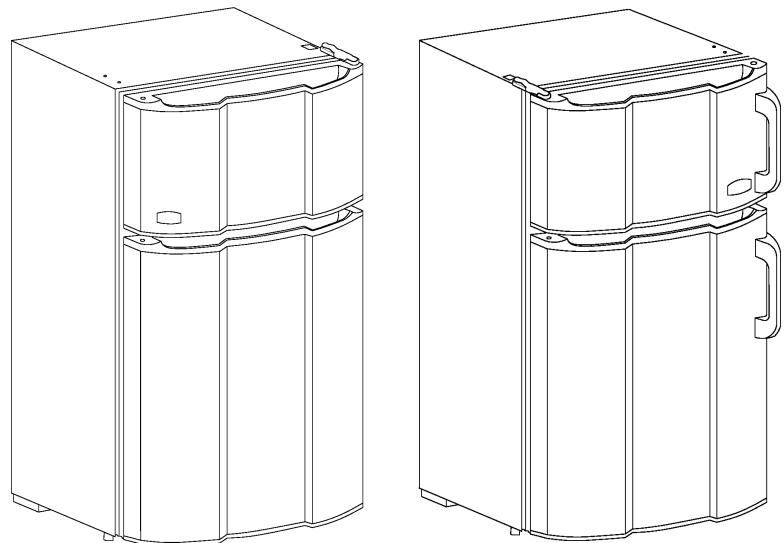

### What is Safe Plug® Technology?

MicroFridge® with Safe Plug® combination appliances utilize Safe Plug® technology, a revolutionary, patented design, to conserve electricity and reduce potential fire hazards that can be caused by overloaded circuits. This technology, built into the microwave, works by temporarily shutting off the power to the refrigerator and charging outlets when the microwave is in use. When the microwave is finished, power to the refrigerator and charging outlets resumes. Engineered with unique one-plug-to-the-wall operation, our combination appliances never draw more than 11-15 amps of current.

MicroFridge® with Safe Plug® uses patented intelligent load monitoring technology to control the microwave, refrigerator and extra outlets. The two charging outlets are designed to conveniently recharge smart phones, tablets, laptops or similar low power devices.

### IMPORTANT WARNING

An empty refrigerator is a very dangerous attraction to children. Remove the gasket, latches, lids or doors from unused appliances, or take some other action that will guarantee the appliance harmless.  
**DANGER:** Risk of child entrapment. Before you throw away your old refrigerator:  
• Take off the doors.  
• Leave the shelves in place so that children may not easily climb in.

**DON'T WAIT! DO IT NOW!**

### ATTENTION

For your protection in the event of theft or loss of refrigerator, fill in spaces provided below.  
Model and Serial Numbers are indicated on the inside right liner of the refrigerator.

MODEL No. \_\_\_\_\_  
SERIAL No. \_\_\_\_\_

## Where to Place Your MicroFridge® with Safe Plug®

1. This product is designed for free-standing installation only.
2. Select a location with a strong level floor. If the floor is not quite level, adjust the height of the front legs accordingly. Do not place anything under either one of the front legs or the rear of the unit.
3. A minimum of 2 inches of clearance must be provided between the rear condenser and the wall. Providing greater rear wall clearance when space allows in order to improve air circulation is recommended; in addition, leave unobstructed space above the refrigerator and both sides.
4. Avoid any direct sunlight and heat. Direct sunlight may affect the enamel coating. Heat sources nearby will cause higher electricity consumption.
5. Avoid very moist places. Too much moisture in the air will cause frost to form very quickly on the evaporator and the refrigerator will have to be defrosted more frequently.
6. Your refrigerator is equipped with a three-prong plug and is grounded to eliminate electrical hazards. In order to make it more effective, it must be plugged into a grounded electrical outlet.
7. Plug your refrigerator into the back of the microwave.

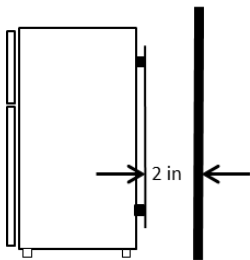

## Test Run Your Refrigerator

Before using your refrigerator, clean it and test run it to see if it is operating properly. If it is not, then check your electrical source. If you cannot locate the source of the problem, contact your dealer.

1. Set the temperature control knob to the *OFF* position and then plug the AC cord into an electrical outlet of 115 volt, 60Hz. The compressor motor should not run.
2. Set the temperature control knob to the *MAX* position and let the refrigerator operate for 20 minutes. The freezer should get slightly frosted and the motor should run smoothly with a soft hum.
3. Rotate the temperature control knob counter-clockwise toward the *MIN* position. Before the pointer of the temperature control knob reaches the *MIN* position, the compressor motor should turn off.

**NOTE:** The refrigerator will not operate when timer of microwave oven is on. This is part of the patented MicroFridge® with Safe Plug® technology that prevents wiring overloads.

## Sound of Flowing is Noticeable

This sound is caused by the refrigerant flowing into the refrigerating device. It does not denote a malfunction.

## How to Remove Ice Cubes from the Tray

The ice cube tray is flexible. Twist the tray to remove the ice cubes. If the ice cube tray is frozen hard to the surface, do not use a knife or other metal instrument to remove it because this may damage the surface.



## Cleaning and Maintenance

Your refrigerator does not require any maintenance.

Turn off your refrigerator and remove all food, shelves, trays, etc. Wash the interior liner with a solution of two tablespoons of baking soda and a quart of warm water. Then, rinse and wipe it out. Do not use soaps, detergents, scouring powders, spray cleaners or the like for cleaning the interior liner. It may cause odors in the refrigerator compartment.

Wash the ice cube trays, drip tray and shelves in a mild detergent solution and dry with a soft cloth. Normal appliance spray cleaners may be used for the exterior only.

Use only mild soap and water to clean the door gasket.

Never use acid, chemical thinners, gasoline, benzene or the like to clean any part of the refrigerator. Boiling water and benzene may deform or damage the plastic parts.

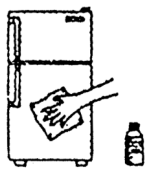

## Cleaning the Evaporating Tray

Since dust accumulated on the evaporating tray will decrease the evaporation efficiency, remove the tray to clean.

The evaporating tray is set on the back of the refrigerator. To remove, pull it away from the unit. After cleaning make sure to put the tray securely back in place otherwise defrosted water may spill or the evaporation process may be hindered.

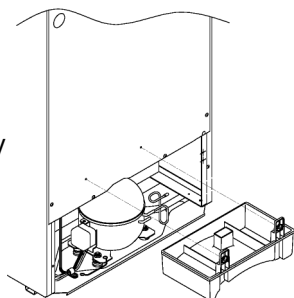

## Hot-Line

With the refrigerator/freezer in operation, it is possible that the cabinet will feel warm at the front edges. This does not indicate trouble. It is attributable to the hot gas line design. This prevents moisture from accumulating and has nothing to do with the storage temperature inside.

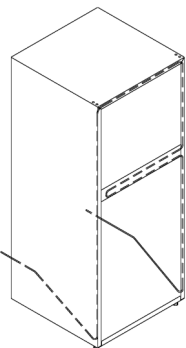

### ATTENTION

If the unit is turned off or unplugged, **YOU MUST ALLOW THREE (3) MINUTES BEFORE RESTARTING OR REPLUGGING THE UNIT.** The unit will not start if you attempt to restart it in less than three (3) minutes.

## Temperature Control

You can Control the temperature inside your refrigerator by turning the thermostat dial. Higher numbers mean greater cooling power, smaller numbers mean less cooling power. Set the temperature control dial to 3 for optimum refrigeration/freezing effects under normal conditions. Set the temperature control dials to *MAX* only when the rapid refrigeration/freezing of foodstuffs in your refrigerator is necessary. Be sure to set it back to 3 later on.

## Important

- Do not operate your refrigerator for more than six hours at a stretch with the temperature control dial set to 5 or *MAX*. At this setting, the compressor will run continuously. Consequently, foodstuffs stored in the refrigerator compartment will be frozen and frost will form on the cooling (evaporator) unit.
- At the control dial setting of 1 the freezer compartment temperature will not remain at a sufficiently low level for ice cream and frozen foods.

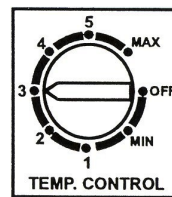

## Before Calling for Service

We urge you to read the chart below. If the problem is not caused by defective workmanship or materials, you may be charged for service calls even during the warranty period. Before calling for service, check these few simple points:

Refrigerator not operating	<ul style="list-style-type: none"> <li>• Is the temperature control dial inside the refrigerator set to OFF?</li> <li>• Is the unit unplugged? Be sure!</li> <li>• Is the fuse blown or the circuit breaker tripped?</li> </ul>
Storage compartment too warm	<ul style="list-style-type: none"> <li>• Has the door been opened frequently? Is it slightly ajar?</li> <li>• Are the shelves overcrowded?</li> <li>• Have large amounts of warm food been added recently?</li> <li>• Are the coils on the back clogged or blocked?</li> <li>• Is the temperature control dial set properly?</li> </ul>
Excessive noise	<ul style="list-style-type: none"> <li>• Is the refrigerator level? (Try to rock it.)</li> <li>• Are dishes vibrating?</li> <li>• Are there objects behind or on top that are shaking?</li> <li>• Does any part of the refrigerator touch the back or side wall?</li> <li>• When the motor comes on, you may hear popping or cracking sounds as metals expand or contract.</li> </ul>
Moisture	<ul style="list-style-type: none"> <li>• Moisture in the storage compartment is normal in humid weather.</li> <li>• Is the door opened frequently? Has the door been left ajar? Does the door fit properly?</li> </ul>

## Changing Door Hinge Location

The door of the refrigerator can be hinged on either side so that the direction they open in can be chosen to suit the place of installation. Refer to the disassembly diagram and change the door hinges according to the following steps:

1. Remove the hinge cap by twisting it off.
2. Remove the upper hexagonal head screws. The freezer door can now be removed.
3. Remove the middle hexagonal head screws. The refrigerator door can now be removed.
4. Remove the hinge-side leg, attach it to the leg hole on the other side.
5. Remove the other leg, attach it to leg hole on the other side.
6. Attach the bottom hinge symmetrically to the other side of the cabinet.
7. Remove the upper hinge plug buttons and insert them in the holes from which the screws were removed in Step 2.
8. Remove the middle hinge plastic cover and remount it to cover the holes from which the screws were removed in Step 3.
9. Remove the door plug button from the top of each door using a screwdriver and insert in the hole on the opposite side of each door.
10. Attach the refrigerator door to the bottom hinge.
11. Rotate the middle hinge 180 degrees. Attach it to the refrigerator door and secure it with a screw. (Do not tighten the screw completely.)
12. Attach the upper hinge to the freezer door. Attach the freezer to the middle hinge and use the screw to attach the upper hinge. (Do not tighten the screw completely.)
13. The direction in which the doors open has now been changed; however, the following points should be checked:
  - A) Make sure both doors are on straight.
  - B) Make sure that there is no space between the door gasket and the refrigerator unit itself when the doors are closed.
  - C) Make sure that the gasket on the hinged side is not caught between the door and the unit when the door is opened or closed. (If the door is forced closed when the gasket is caught, the gasket may be damaged.)
14. After making sure that the doors are installed correctly, tighten all the screws holding the hinges. If they are not tightened, the doors may slip out of position or there may be an opening between the doors and the cabinet.
15. For models with senior living handles, remove the screws holding the handle on the door. Remove plastic pins from the other side of the door and insert them into the holes where the screws were removed. Re-install the handle using the same screws that were removed from the door handles.

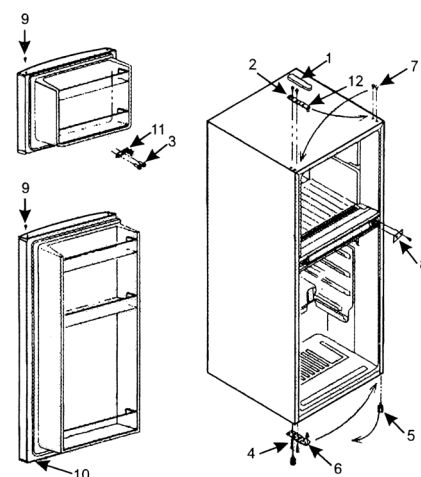

## Installing the Hinge Clip

1. Remove Cord Retaining Clip from bag.

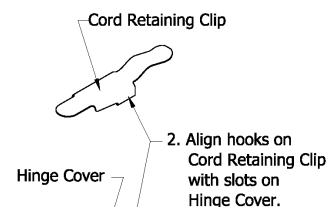

2. Align hooks on Cord Retaining Clip with slots on Hinge Cover.

3. Push Cord Retaining Clip onto Hinge Cover, one hook at a time.

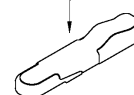

### WARNING

Do not route high-voltage electrical cords underneath the hinge clip. Only use the clip to cover low-voltage cords.